



QA Technology Company, Inc.

Applications Note integraMate™ DO2 Series Connectors Wire Preparation & Contact Removal

Document# AP10000

Rev A

ECN# iM0041

Page 1 of 1

Wire Preparation-

These are the cable jacket and wire strip lengths recommended for crimp and solder cup termination, they apply to both pin and socket contacts.

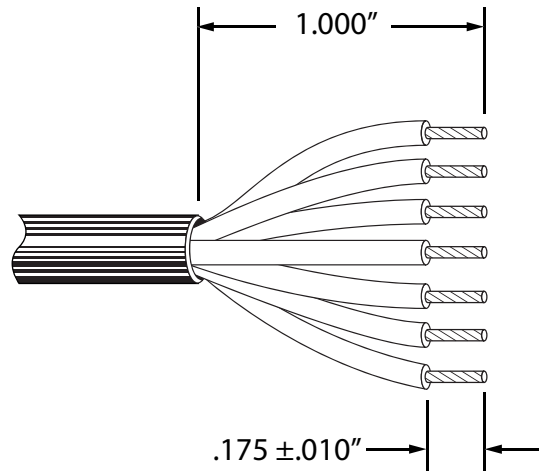

Contact Removal-

ITE-O60 (0.6mm) and ITE-OA5 (1.5mm) Extraction Tools are used to remove both pin and socket contacts from either the receptacle housing or the plug contact insert. This makes repair and replacement of contacts easy.



ITE extraction tools have a spring loaded coaxial mechanism, this is how they work:

- Step 1:** Insert the tool tip around the pin/socket contact and push forward.
- Step 2:** The outer sleeve closes the tines of the pin/socket retention clip and releases the pin/socket.
- Step 3:** The inner sleeve now moves forward and ejects the pin/socket through the back of the contact housing.

