



QA Technology Company, Inc.

# Applications Note

## Instruction for Using Adjustable Tools

Document# D10044

Rev B

ECN# 3109

Page 1 of 1

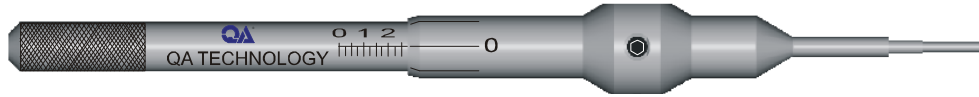

The adjustable installation tools are used to install sockets at any set height from flush to the maximum possible for a particular socket. The set height is adjusted via a built-in micrometer and locked at the desired height. The set height can be changed and the tool reused as often as needed.

Part Number	Socket Family	Set Height Range in (mm)
AT100-KIT *AT100M-KIT	100-SD□160□	Flush to .190 (4.83)
	100-SD□250□	Flush to .250 (6.35)
	100-SD□251□	Flush to .345 (8.76)
A75-KIT *AT75M-KIT	075-SD□250□	Flush to .250 (6.35)
	075-SD□251□	Flush to .345 (8.76)
AT50-KIT *AT50M-KIT	050-S□B255□	Flush to .270 (6.86)
	050-SBB160/2□	Flush to .270 (6.86)
	050-SBB161/3□	Flush to .360 (9.14)

### Setting and Reading the Socket Set Height:

Adjusting the set height on QA's adjustable tools is the same as using a micrometer. The tool handle has markings from zero to .350" (9mm) in .025" (0.5mm) increments, and the thimble has markings in .005" (0.1mm) increments around its circumference. Each full rotation of the thimble changes the set height by .025" (0.5mm). Examples of various set heights are shown at right.

### Locking the Thimble:

Using the supplied hex key wrench, tighten both set screws on the thimble to lock it in place. To change the tool's set height, loosen both screws, dial the thimble to the new set height, and re-tighten the screws.

\*These tools are in metric units (mm).

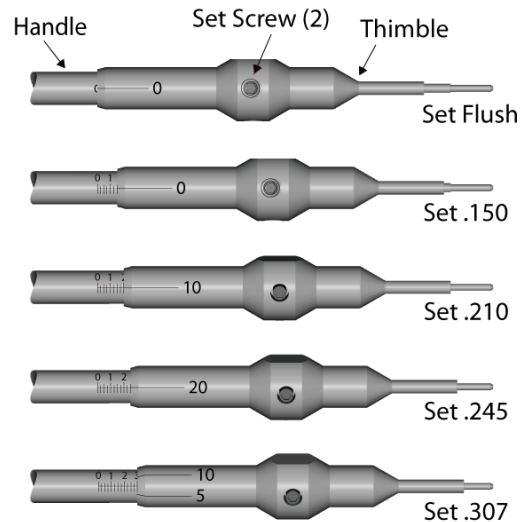

Examples of set heights for AT 100

### Important Notes:

The thimble can be dialed *past* the zero position to negative set heights. Dialing the thimble until it stops does not set the tool flush – see the Set Flush example. The Handle and Thimble are calibrated as a matched set. Do not separate tool parts or swap parts with any other adjustable tool. These are precision tools and should be handled as such. No maintenance is required.

It is recommended that a 4 to 6 ounce (110-170 gram) hammer be used for socket installation. Damaged sockets and broken tools indicate that the socket mounting hole is too small. Always check the finished hole sizes with the appropriate PG (Pin Gauge tools) to ensure that the holes are correct for the sockets being used.

The plastic Nose protector that is shipped with this tool should be installed whenever the tool is not being used. This will prevent the Guide Pin and Stop Nose from being damaged if the tool is dropped.