



Applications Note

X Probe Termination Pin Set Heights

Calculations

X Probe Termination Pin set height is a critical factor in the performance and life of the X Probe. When set too low, the X Probe is under-stroked, reducing the contact force and the X Probe's ability to penetrate surface contaminants. When set too high, the X Probe is over-stroked, resulting in decreased spring life or possible tip damage due to bottoming. To calculate proper set height, follow these steps:

- 1) Make a cross-sectional sketch of the fixture in the actuated position. The sketch at right is typical of many vacuum fixtures.
- 2) Dimension the thickness of the items that stack up on the top surface of the probe mounting plate. Add these dimensions to get a final distance (H) from the top of the plate to the contact surface of the UUT. Subtract the average lead length from this dimension if contacting leaded components.
- 3) (A) is the distance from the UUT to the top of the back plate.
- 4) (C) is the X Probe tube length (see table).
- 5) (P) is the distance from the X Probe tip to the top of the X Probe tube (see table). Remember this dimension is with the X probe compressed to its recommended working travel.

(A) = (H) + .375(9.53) (probe plate) + .563(14.29) (optional spacer plate). Use actual plate thickness or standoff lengths as per your design. Proper set height = (A) - (C) - (P)

Example for X39-25 Series:

H = Spacer + Support Plate + Board Stop
 = .062(1.58) + .196(4.98) + .125(3.18) = .383(9.74)

P = .105(2.67) (from table)

Set Height = (A) - (C) - (P)
 1.321(33.55) - 1.178(29.92) - .105(2.67) = **.038(0.97)**

Related Notes:

To mix X Probe series within a fixture, calculate the proper set height for each series used in the fixture.

Thicker mounting plates allow the greatest set height range, but hole straightness may suffer.

For dual level testing, .400(10.16 mm) stroke X Probes are mounted in the same termination pins, at the same set height, as standard .250(6.35 mm) stroke X Probes. As a result, they can be interchanged freely from one termination to another as test needs dictate.

* See "Decreased Stroke Probe (-D Option)" apps note (D10059) for more information.

**To account for irregularities at the hole ends, a margin of at least .020(0.51) is recommended between the press ring and the closest plate surface.

*** When installing the X39 termination pin for the .250 [6.35] stroke probe for dual level testing, termination pin must be set .015 [.38] higher to achieve the designed .150 tip height difference when the fixture is not actuated.

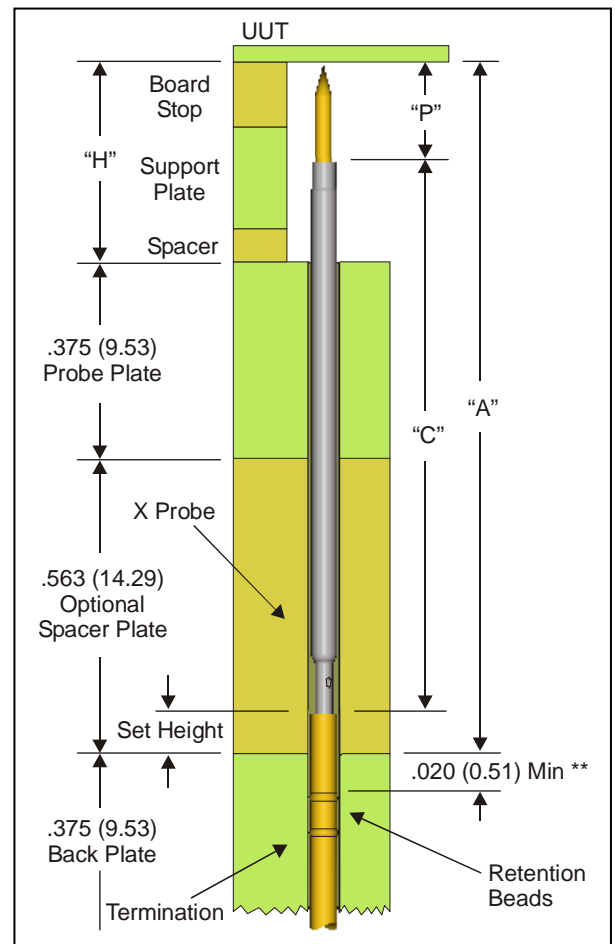

Key Dimensions for Calculating Set Height		
Series	X Probe Tube Length C	Recommended Extension P
X39-25	1.178 (29.92)	.105 (2.67)
X39-40	1.178 (29.92)	.120 (3.05)
X39-40-D***	1.178 (29.92)	.270 (6.86)
X50-25	1.110 (28.19)	.133 (3.38)
X50-40	1.110 (28.19)	.133 (3.38)
X50-40-D*	1.110 (28.19)	.283 (7.19)
X75-25	1.100 (27.94)	.143 (3.63)
X75-40	1.100 (27.94)	.143 (3.63)
X75-40-D*	1.100 (27.94)	.293 (7.44)

All dimensions are in inches (mm)